



LIVING BETTER



The indoor climate solution of the future

HEAT, VENTILATION AND GOOD INDOOR CLIMATE

- AS SIMPLE AS THAT



HEAT, DOMESTIC HOT WATER AND VENTILATION IN AN ALL-IN-ONE SOLUTION

Thanks to new technology, as a construction client you can now get effective heating and ventilation in a highly consolidated concept that provides you with comfort, good indoor climate and low operating costs.

With LivingBetter, you get what is perhaps the simplest heat and indoor climate solution in the world. At the same time, you can avoid high connection fees to existing heat supplies in the area or the expensive costs associated with alternatives such as geothermal energy. As an added bonus you also save on the cost of installing a heat recovery system as ventilation is an integrated part of the LivingBetter solution.

Innovative, simple and effective

THAT IS HOW IT WORKS

LivingBetter in all its simplicity consists of windows with built-in ventilation – so-called ventilation windows supplied by LivingBetter – combined with a new type of highly efficient exhaust air heat pump which provides both heat and domestic hot water.

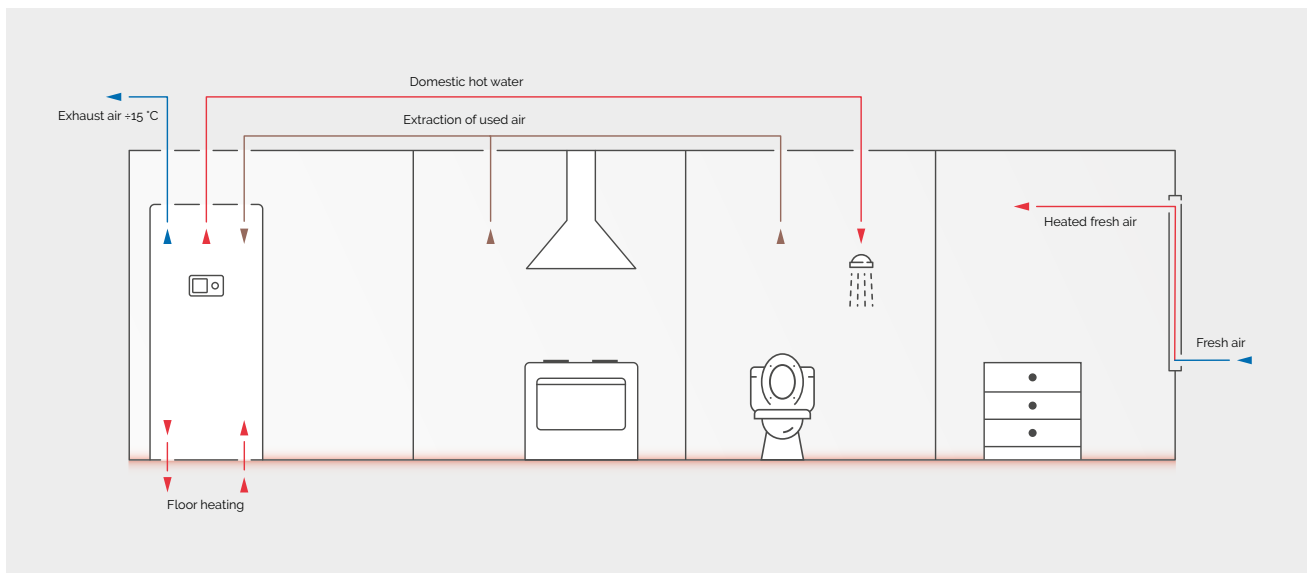

The exhaust air heat pump, which is located in the utility or control room, needs to be supplied with air in order to produce heat and hot water.

This air is brought in from the ventilation windows, where it is heated up using the forces of nature itself. This makes the heat pump more efficient. As part of the same process, the pump extracts exhaust air from the building's rooms and uses the surplus heat and energy in the air to produce new heat. It is a healthy cycle which requires minimal power supply.

HEALTHY INDOOR CLIMATE – HEALTHY FINANCES

The indoor climate speaks for itself, and the

operational costs for the solution are lower than the cheapest traditional options, such as district heating. The cost of operating the heat pump, which provides ventilation, heat and domestic hot water, is considerably less than the price of other traditional energy solutions.

FULL DOCUMENTATION

The ventilation window, the heat pump technology and the LivingBetter concept as a whole are all able to meet applicable requirements for the construction sector in accordance with BR15 and BR20. The necessary energy framework data for the recording of significant energy savings in BE15 or similar calculation programmes is made available in each individual building project.

HEALTHY REFERENCES

The simplest indoor climate solution in the world is already installed and running in a large number of private villas, terraced houses and institutions.

LivingBetter is recommended as an indoor climate solution by innovative architects and construction firms, including EEN TIL EEN, the Danish firm behind 'Det Biologiske Hus' (The Biological House) eco-home concept, and by Jakobsen Huse, who specialises in the construction of sustainable housing. Demand is massive and development is going strong.

New references are constantly coming in as a result. Contact us for more information about current reference projects.



LivingBetter for new single-family homes

OPTIMAL COMFORT AND HEALTHY FINANCES

Building a new house is a huge undertaking, and there is lots to consider during the construction process. Two of the key areas are indoor climate and the type of heating system to be used. Both factors are relevant to your finances, well-being and environment. LivingBetter is a new way of thinking about heating and ventilation. The costs for installation and the ongoing operations are attractive and the comfort provided is second to none.

LivingBetter is a strong and green alternative to conventional heating and ventilation solutions.

At the same time, you can avoid high connection fees to existing heat supplies in the area or the high costs associated with alternatives such as geothermal energy. As an added bonus, you also save on the cost of installing a heat recovery system as ventilation is an integrated part of the LivingBetter solution.

Simply put, you install the ventilation windows throughout the house and the heat pump in the utility room, and just like that, your new heat and ventilation solution will be up and running.



MEETS THE REQUIREMENTS IN BR15 AND BR20

The LivingBetter solution meets the strict requirements on indoor climate and renewed air supply set out in the latest Danish building regulations BR15 and BR20.

IKM Heat Pump Technology

MAXIMUM RECOVERY AND SIMPLE SYSTEM DEMAND CONTROL OF VENTILATION

EFFECTIVE USE OF SURPLUS HEAT AND ENERGY

At the heart of the LivingBetter solution is the innovative IKM exhaust air heat pumps, which utilise energy in the warm ventilation air that is extracted from the building.



IKM EX

INTELLIGENT AND EFFECTIVE



IKM EX is the obvious choice of heat pump for single-family homes. The heat pump can extract enough energy from exhaust air to cover the property's heat requirements and the family's use of domestic hot water.

PLENTY OF HOT WATER – NO MATTER THE TIME OF YEAR

IKM EX is typically supplied with a 210 litre tank for domestic water, which is heated up by the heat pump. The built-in heating element takes over automatically if the heat pump alone is not enough – i.e. when lots of hot water is being used or on a really cold winter's day. The heat pump is prepared for the operation of all heat systems in the property such as floor heating or radiator installations.

INTELLIGENT AND FLEXIBLE CONTROL

Controls can be set individually for many different needs, and the heat pump can even be controlled from a distance via an app for smartphones and tablets.

AWARD WINNING DESIGN AND SWEDISH QUALITY

IKM EX stands out as a super simple all-in-one design module at just 60x60 cm and with a height of up to 210 cm. This means that the heat pump fits all standard element dimensions and its prize-winning design is surprisingly elegant. The fact that the heat pump is produced in Sweden and built to handle the Nordic climate is yet one more guarantee of quality.



IKM VL – THE HIGH-PERFORMANCE HEAT PUMP FOR LARGER PROJECTS

IKM VL is a high-performance exhaust air heat pump for the optimal use of the energy in exhaust air. The VL-series is used with larger buildings, apartment buildings, offices, institutions, etc. Comes complete with control system that can be connected to MODBUS. The Danish-produced VL series is perfect for new buildings and energy renovation.

LivingBetter for apartment buildings being renovated

BETTER INDOOR CLIMATE AND HUGE SAVINGS

The LivingBetter solution opens up whole new possibilities for establishing a good indoor climate in apartment buildings with minimal work required in the building and attractive energy costs.



Up until now, it has been a complex and demanding task to improve the indoor climate in older apartment buildings in a way that brings them in line with modern standards. It doesn't have to be like that any more.

With LivingBetter's combination of ventilation windows and a central exhaust air heat pump, you are guaranteed a constant supply of fresh air to the various units.

As the existing ventilation piping can typically

be used, there is no need for any larger works to be undertaken in the building. Simply put, the windows are replaced and the heat pump is installed in the loft, and from then on energy is returned to the building and its residents.

The building is quickly up and running with a noticeably higher degree of comfort for its residents. The building's owner gets a cost-effective energy renovation without any costly re-homing expenses.

THE PREINSTALLATION PRINCIPLE FOR IKM IN APARTMENT BUILDINGS

The recovery of energy using IKM VL exhaust air heat pump greatly reduces the cost of heating and domestic hot water.

The energy that is extracted is re-used with high efficiency, and so when it comes to renovations, this means that a significant part of the heating money goes directly back into your account.

The solution provides the option for individual demand-control of extraction from single dwellings right down to the room level.

We call it “intelligent demand-driven air renewal” and the solution can be combined with all forms of system demand-controls and data capture technologies, such as IC meters.

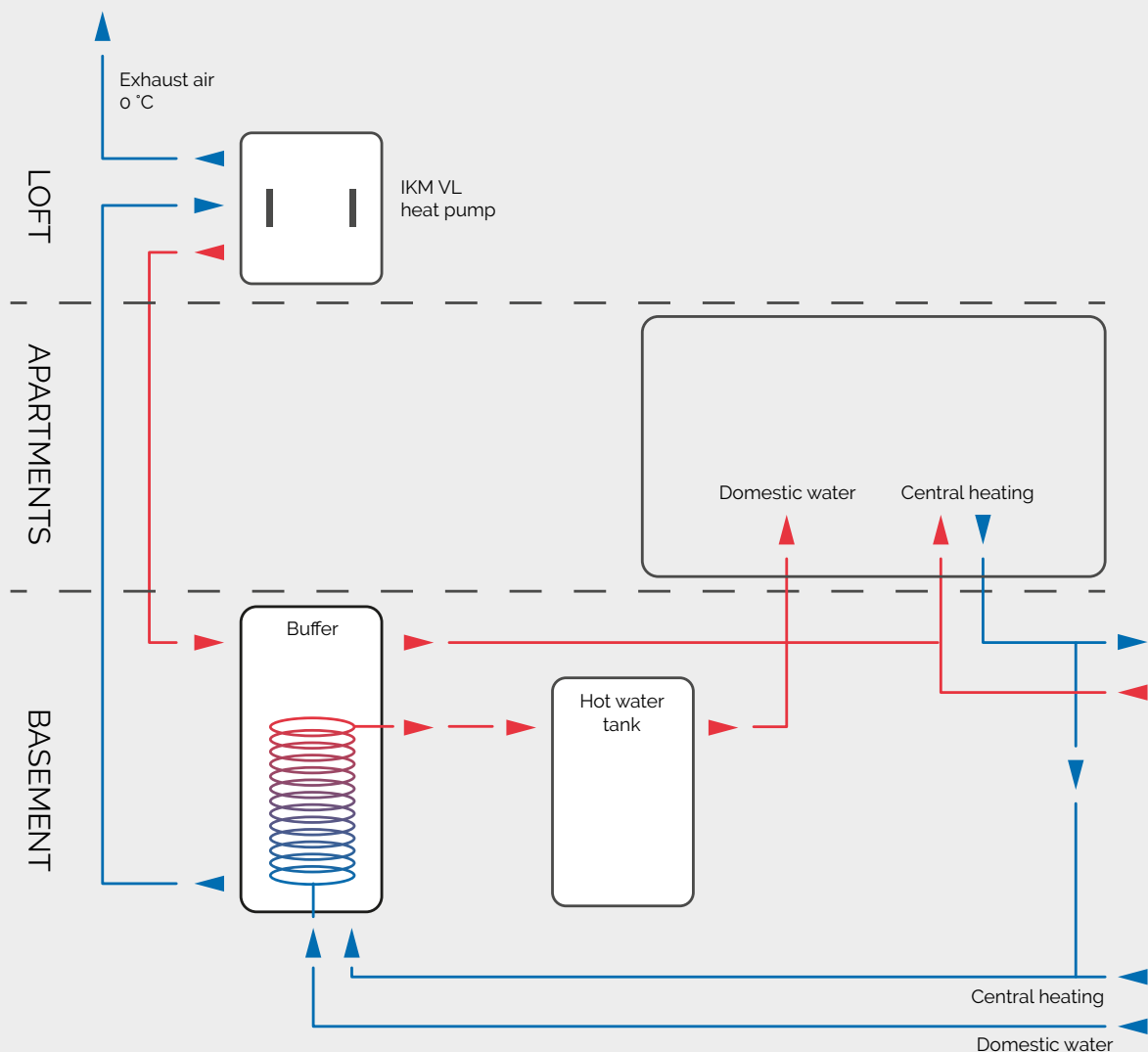



Tradition meets innovation

THE ORIGINAL VENTILATION WINDOWS

The ventilation window by LivingBetter looks just like a traditional window. But don't be fooled by its simple appearance. The ventilation window has an advanced built-in technology which ensures a constant supply of fresh, heated air – using the forces of nature itself. In combination with the modern exhaust air heat pump, the ventilation window provides comfort, indoor climate and low operating costs that cannot be matched.

The ventilation windows are the key to attaining a supply of fresh air to a building with minimal energy loss and maximum comfort without draughts and in quantities that meet the requirements set out in building regulations..

MORE THAN A WINDOW

Up until now the purpose of a window has been to let in light and provide a view. It doesn't have to be like that any more. The original ventilation window from LivingBetter is more than just a window. It is a climate and energy solution that ensures a constant supply of fresh, heated air using the forces of nature itself.

BETTER INDOOR CLIMATE

New houses must be hermetically sealed. This is a requirement. But it is not ideal when it comes to the indoor climate. In order to avoid problems with dampness, mould and bad air, it is important to frequently air out the property, but many do not manage to do this sufficiently – especially not in the colder months.

This is where the ventilation window comes into the picture. Thanks to its intelligent ClimaWin valves and unique double-ply design, the ventilation window ensures an even supply of fresh, heated air, all year round.

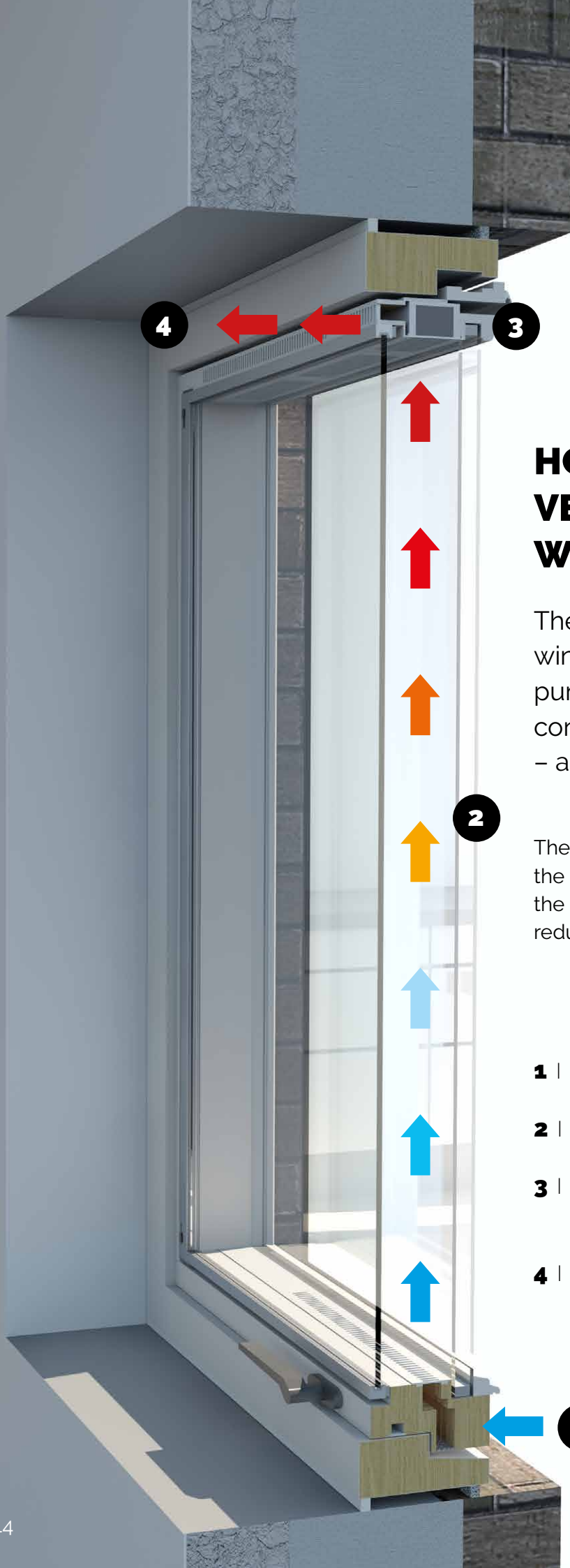

HOW THE VENTILATION WINDOW WORKS

The combination of the ventilation window and the exhaust air heat pump ensures an effective and constant supply of fresh, heated air – all day and all year.

The constant supply of fresh air improves the indoor climate considerably, minimising the risk of mould, increasing comfort and reducing energy loss.

- 1** | The cold fresh air is pulled in through the valve at the bottom of the window
- 2** | The fresh air is heated up between the window's two layers of glass
- 3** | The patented Climawin valve opens automatically whenever the air reaches a given temperature
- 4** | The fresh, heated air flows into the building

The result of many years development work

THOROUGHLY TESTED AND DOCUMENTED

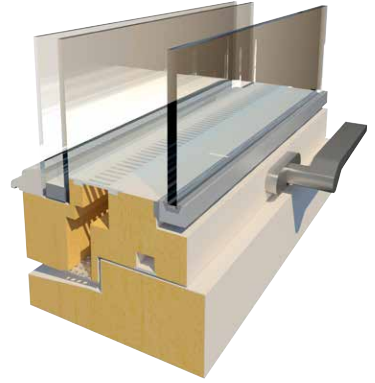

The technology behind the ventilation window is thoroughly tested and fully documented, and the renewed air supply meets the strict requirements established by Danish building regulations.

WELL-DOCUMENTED QUALITIES

The ventilation window, which has been developed in Denmark over the course of many years, has undergone comprehensive testing and has well-documented qualities which provide completely new opportunities for indoor climate and energy solutions when it comes to both renovations and new-builds that need a good indoor climate while also meeting strict sealing requirements.

TESTED BY FRAUNHOFER AND AALBORG UNIVERSITY

The windows' intelligent valve system, which is designed to function across the entire service life of the window, is patented and has been tested by the German research organisation Fraunhofer-Gesellschaft. Aalborg university has used the test results to develop a calculation programme which puts LivingBetter in a position to provide documentation on the energy.



FOR ALL BUILDING TYPES

The ventilation window comes in three different series which are each designed for different types of architecture.

The VENT 1900 series is well suited to older buildings, while the VENT 2000 series is designed for modern buildings. All windows can be delivered in wood or a wood-aluminum combo and in the colour of your choice.

THE FORCES BEHIND LIVING BETTER

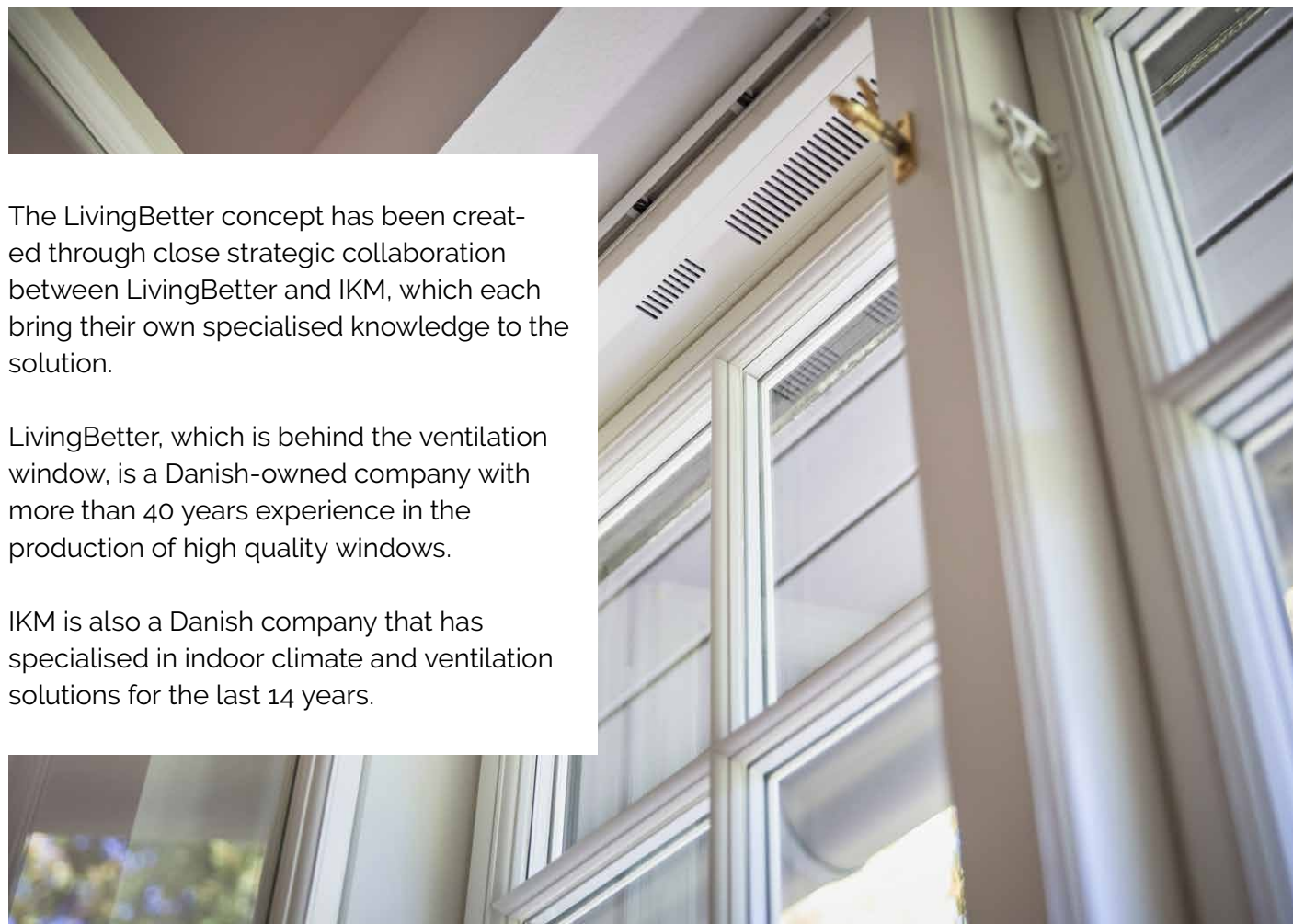

The LivingBetter concept has been created through close strategic collaboration between LivingBetter and IKM, which each bring their own specialised knowledge to the solution.

LivingBetter, which is behind the ventilation window, is a Danish-owned company with more than 40 years experience in the production of high quality windows.

IKM is also a Danish company that has specialised in indoor climate and ventilation solutions for the last 14 years.



+45 2947 9955
ct@livingbetter.dk
livingbetter.as

Read more at ventilationsvinduet.dk or contact us at (+45) 8181 8110 for an informal chat about the many opportunities offered by the simplest indoor climate solution in the world.